

PRODUCT DIMENSIONS

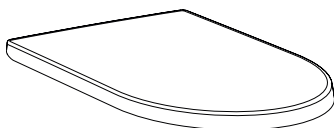

PRODUCT CONTENT

Pos.	Article no.	Article no. VIGOUR	Description	Quantity	Remarks
1	NW3835 T04.0554.00.02	WHSETWWCOSP	Toilet wall-hung	1	
2	U7490S-W-CYS1 S04.0200.04.02	WHSIANAS	Toilet seat, UREA	1	
3	110015310100 A92.0100.01.02		Smart fix - top fixation	1	Box
4	224000058010 CI_Z04.1300.09.02	CI_Z04.1300.09.02	Cleaning instruction	1	A4 paper , 120g
5	224000085100 MI_Z04.1201.00.02	MI_Z04.1201.00.02	Manual instruction	1	A5 paper , 120g
6	221053000100		Side protection	1	Carton
7	221000060100		Outer box	1	brown cardboard VIGOUR customized, printing 1-colour in Pantone 321 C
8	220000106500 PL_T04.0554.00.02		Etikette	2	white VIGOUR customized
9	225000279902 PL_T04.0554.00.02		CE Etikette	1	white VIGOUR customized
10	225000199001 MI_X10.0000.1704.0		Flow regulator	1	A5 paper yellow, 120g

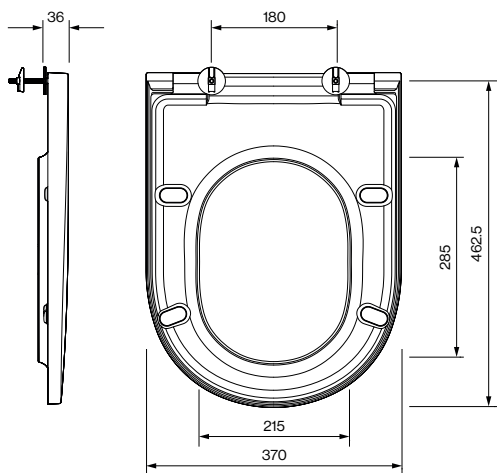
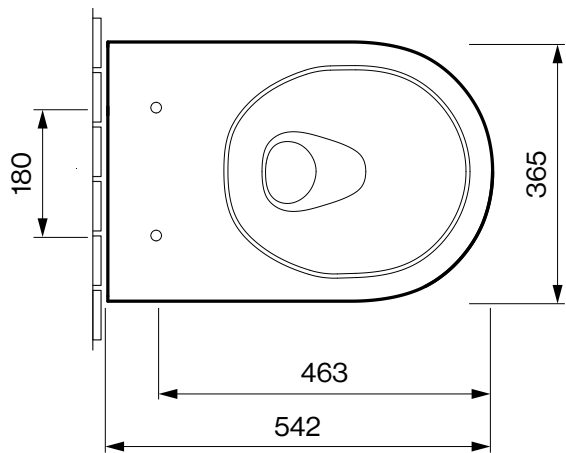
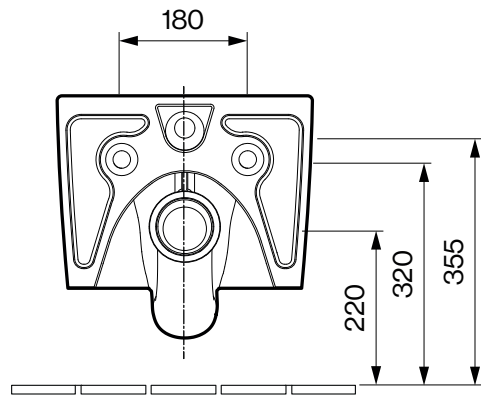
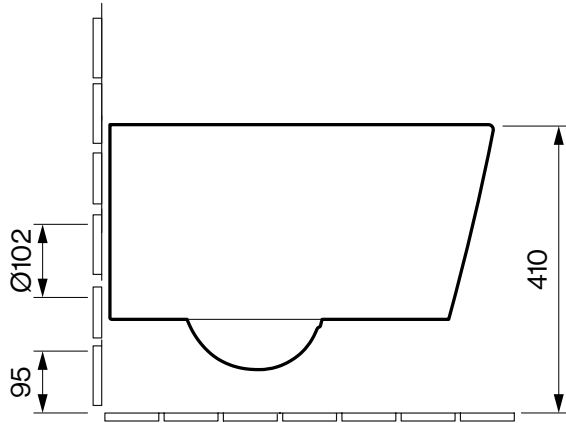
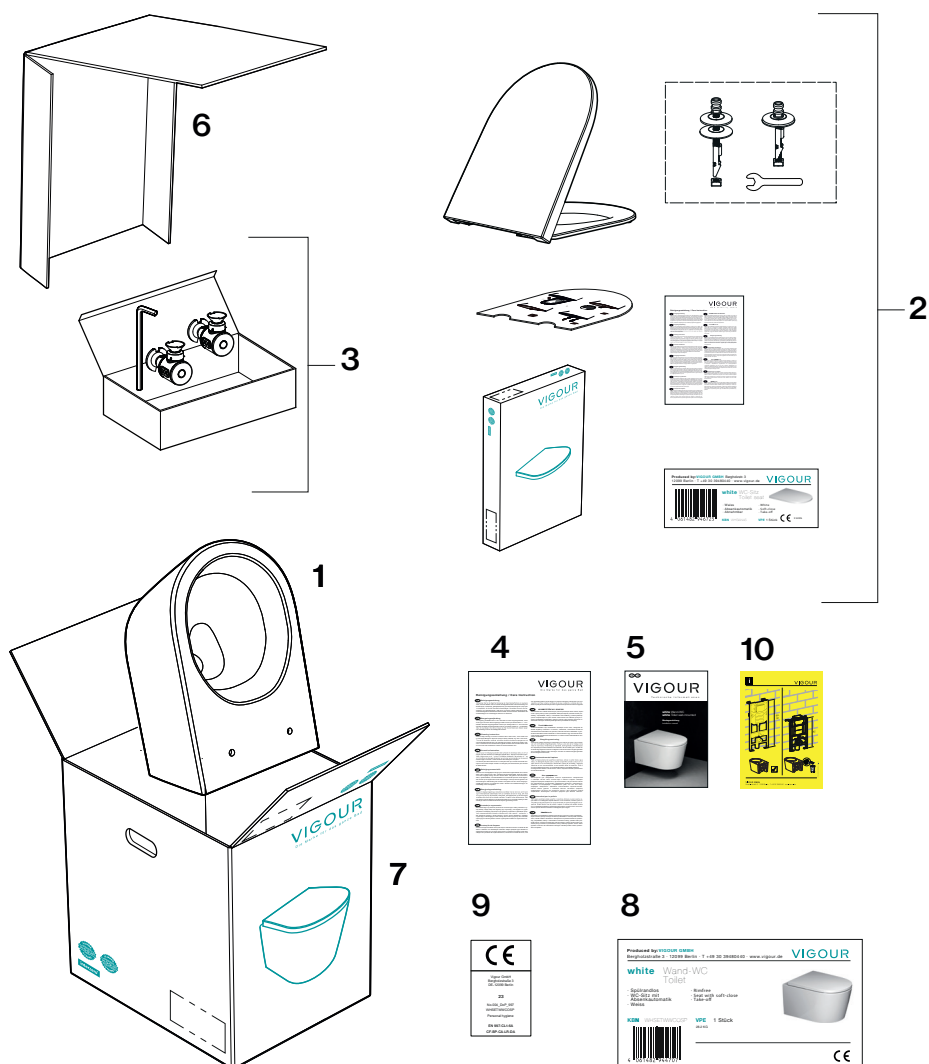

PRODUCT CONTENT

Pos.	Article no.	Art.No VIGOUR	Description	Quantity	Remarks
1	U7410S S04.0200.04.02	WHSIANAS	Toilet seat, soft close, UREA	1	Paper bag
2	X01.0003.00.01		Fixation set for toilet seat	1	Paper bag
3	TE_S04.0200.04.02		Template/Gauge with installation instruction	1	brown cardboard printing 1-colour in black
4	CI_Z04.1301.09.02	CI_Z04.1304.09.02	Cleaning instruction	1	A4 Paper, 120 g
5			Single box	1	brown cardboard VIGOUR customized, printing 1-colour in Pantone 321 C
6	PL_S040200.04.02		Single box label	1	white VIGOUR customized

